



### ■ Features

- 5"×3" miniature size
- Universal AC input / Full range
- Built-in active PFC function
- EMI Class B for both Class I (with FG) and Class II (without FG) configuration
- No load power consumption < 0.5W
- High efficiency up to 94%
- Protections: Short circuit / Overload / Over voltage / Over temperature
- Cooling by free air convection for 250W and 400W with 25CFM forced air
- Built-in 12V/0.5A FAN supply
- Standby 5V@1A with fan , 0.6A without fan
- Built-in remote sense function
- LED indicator for power on
- Output 18V available
- 3 years warranty

### ■ Applications

- Industrial automation machinery
- Industrial control system
- Mechanical and electrical equipment
- Electronic instruments, equipments or apparatus

### ■ Description

EPP-400 is a 400W highly reliable green PCB type power supply with a high power density on the 5" by 3" footprint. It accepts 80~264VAC input and offers various output voltages between 12V and 48V.

The working efficiency is up to 94% and the extremely low no load power consumption is down below 0.5W. EPP-400 is able to be used for both Class I (with FG) and Class II (no FG) system design. EPP-400 is equipped with complete protection functions; it is complied with the international safety regulations such as TUV EN60950-1, UL60950-1 and IEC60950-1. EPP-400 series serves as a high price-to-performance power supply solution for various industrial applications.

### ■ Model Encoding

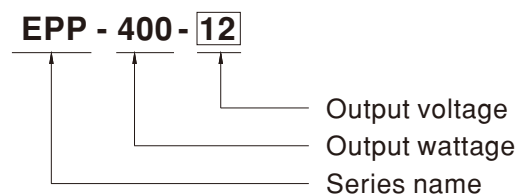

**SPECIFICATION**

MODEL		EPP-400-12	EPP-400-15	EPP-400-24	EPP-400-27	EPP-400-36	EPP-400-48	
OUTPUT	DC VOLTAGE	12V	15V	24V	27V	36V	48V	
	CURRENT	25CFM	33.3A	26.7A	16.7A	14.9A	11.2A	8.4A
		Convection	20.8A	16.7A	10.5A	9.3A	7A	5.3A
	RATED POWER	25CFM	399.6W	400.5W	400.8W	402.3W	403.2W	403.2W
		Convection	249.6W	250.5W	252W	251.1W	252W	254.4W
	RIPPLE & NOISE (max.) Note.2	120mVp-p	150mVp-p	200mVp-p	200mVp-p	250mVp-p	250mVp-p	
	VOLTAGE ADJ. RANGE(MAIN OUTPUT)	11.4~12.6V	14.3~15.8V	22.8~25.2V	25.6 ~ 28.4V	34.2 ~37.8V	45.6 ~50.4V	
	VOLTAGE TOLERANCE Note.3	±3.0%	±3.0%	±2.0%	±1.0%	±1.0%	±1.0%	
	LINE REGULATION	±0.5%	±0.5%	±0.5%	±0.5%	±0.5%	±0.5%	
	LOAD REGULATION	±1.0%	±1.0%	±1.0%	±1.0%	±1.0%	±1.0%	
SETUP, RISE TIME	1000ms, 30ms/230VAC      1500ms, 30ms/115VAC at full load							
HOLD UP TIME (Typ.)	16ms/230VAC      12ms/115VAC at full load							
INPUT	VOLTAGE RANGE Note.4	80 ~ 264VAC      113 ~ 370VDC						
	FREQUENCY RANGE	47 ~ 63Hz						
	POWER FACTOR	PF>0.94/230VAC PF>0.98/115VAC at full load						
	EFFICIENCY (Typ.)	91.5%	92%	93%	93.5%	93%	94%	
	AC CURRENT (Typ.)	4.2A/115VAC      2.1A/230VAC						
	INRUSH CURRENT (Typ.)	COLD START 40A/115VAC      80A/230VAC						
	LEAKAGE CURRENT	<0.75mA / 240VAC						
PROTECTION	OVERLOAD	105 ~ 135% rated output power Protection type : Hiccup mode, recovers automatically after fault condition is removed						
	OVER VOLTAGE	13.2 ~ 15.6V	16.5 ~ 19.5V	26.4 ~ 31.2V	29.7 ~ 35.1V	39.6 ~ 46.8V	52.8 ~ 62.4V	
	OVER TEMPERATURE	Protection type : Shut down o/p voltage, recovers automatically after temperature goes down						
FUNCTION	5V STANDBY	5VSB : 5V@0.6A without fan, 1A with fan 25CFM ; tolerance ±2%, ripple : 120mVp-p(max.)						
	FAN SUPPLY	12V@0.5A for driving a fan ; tolerance ±10%						
	PS-ON INPUT SIGNAL	Power on: PS-ON = "Hi" or " > 2 ~ 5V" ; Power off: PS-ON = "Low" or " < 0 ~ 0.5V"						
	POWER GOOD / POWER FAIL	500ms>PG>10ms ; The TTL signal goes high with 10ms to 500ms delay after power set up ; The TTL signal goes low at least 1ms before Vo below 90% of rated value						
ENVIRONMENT	WORKING TEMP.	-30 ~ +70°C (Refer to "Derating Curve")						
	WORKING HUMIDITY	20 ~ 90% RH non-condensing						
	STORAGE TEMP., HUMIDITY	-40 ~ +85°C, 10 ~ 95% RH						
	TEMP. COEFFICIENT	±0.03%/°C (0 ~ 50°C)						
	VIBRATION	10 ~ 500Hz, 2G 10min./1cycle, 60min. each along X, Y, Z axes						
SAFETY & EMC (Note 5)	SAFETY STANDARDS	UL60950-1, TUV EN60950-1, IEC60950-1 approved						
	WITHSTAND VOLTAGE	I/P-O/P:3KVAC    I/P-FG:2KVAC    O/P-FG:0.5KVAC						
	ISOLATION RESISTANCE	I/P-O/P, I/P-FG:100M Ohms / 500VDC / 25°C / 70% RH						
	EMC EMISSION	Compliance to EN55032 (CISPR32) Class B, EN61000-3-2,-3						
	EMC IMMUNITY	Compliance to EN61000-4-2,3,4,5,6,8,11, EN55024, EN61000-6-2, heavy industry level, criteria A						
OTHERS	MTBF	194.1Khrs min.    MIL-HDBK-217F (25°C)						
	DIMENSION	127*76.2*35mm (L*W*H)						
	PACKING	0.39Kg; 36pcs/15Kg/1.03CUFT						
NOTE	<p>1. All parameters NOT specially mentioned are measured at 230VAC input, rated load and 25 of ambient temperature.</p> <p>2. Ripple &amp; noise are measured at 20MHz of bandwidth by using a 12" twisted pair-wire terminated with a 0.1uf &amp; 47uf parallel capacitor.</p> <p>3. Tolerance : includes set up tolerance, line regulation and load regulation.</p> <p>4. Derating may be needed under low input voltages. Please check the derating curve for more details.</p> <p>5. Touch current was measured from primary input to DC output.</p> <p>6. The power supply is considered a component which will be installed into a final equipment. All the Class I (with FG) EMC test are been executed by mounting the unit on a 360mm*360mm metal plate with 1mm of thickness. The ClassII (without FG) EMC test is been executed by mounting the unit on a 130mm*86.6mm metal plate with 1mm of thickness. final equipment must be re-confirmed that it still meets EMC directives. For guidance on how to perform these EMC tests, please refer to "EMI testing of component power supplies." (as available on <a href="http://www.meanwell.com">http://www.meanwell.com</a>)</p>							

Note: all features are subject to change without notice.

■ Block Diagram

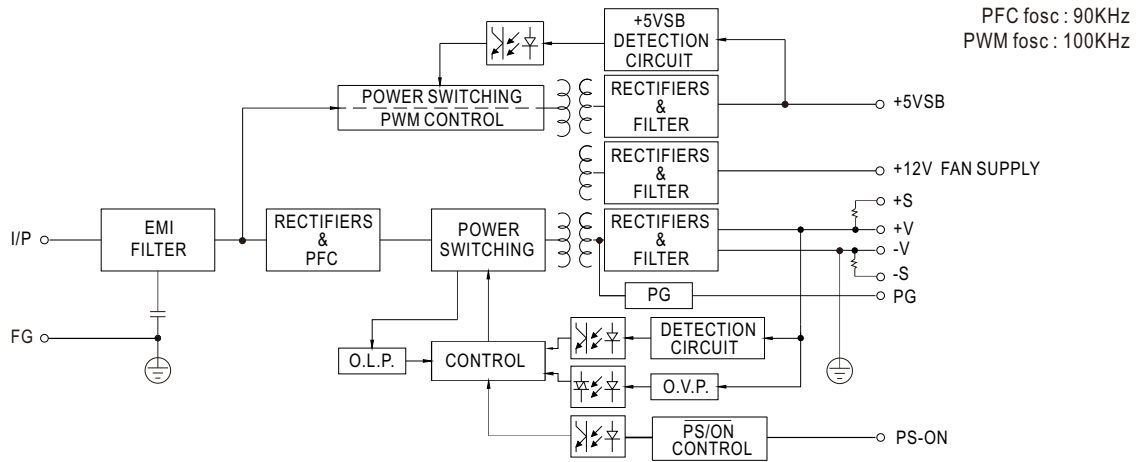

■ Derating Curve

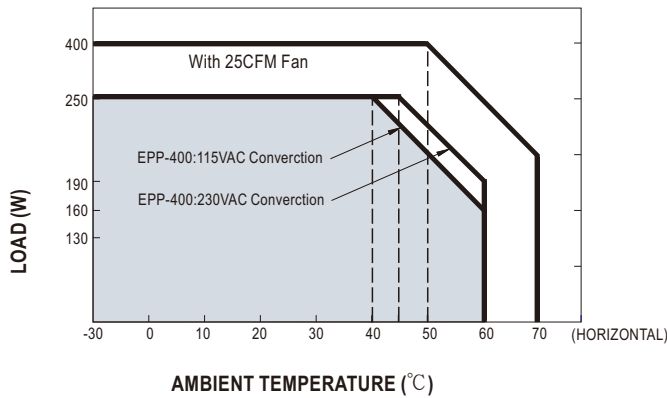

■ Output Derating VS Input Voltage

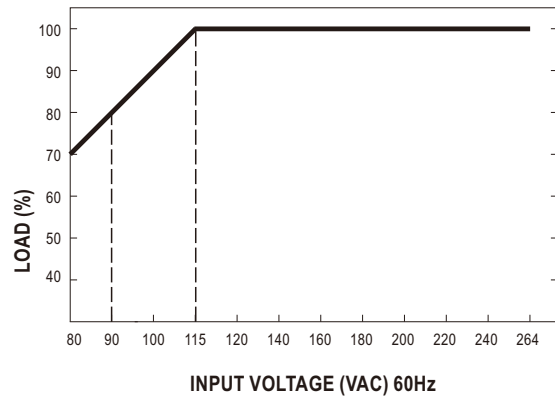

Without Fan Watt	250W
With Fan Watt	400W

**Mechanical Specification**

Unit:mm

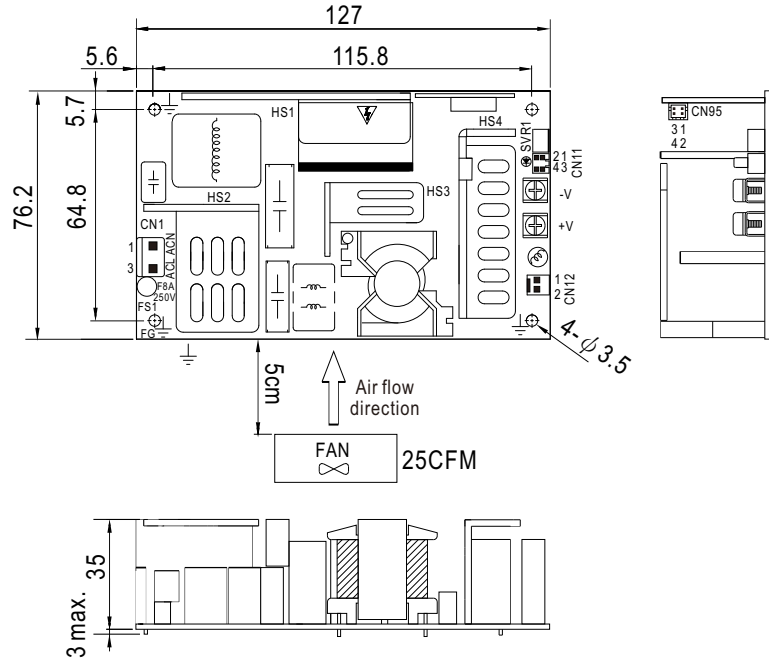

AC Input Connector (CN1) : JST B3P-VH or equivalent

Pin No.	Assignment	Mating Housing	Terminal
1	AC/N	JST VHR or equivalent	JST SVH-21T-P1.1 or equivalent
2	No Pin		
3	AC/L		

DC Output Connector (CN2,CN3)

Pin No.	Assignment	Output Terminals
CN2	-V	M3.5 Pan HD screw in 2 positions Torque to 8 lbs-in(90cNm)max.
CN3	+V	

Function Connector(CN95): TKP DH2L-2X2 or equivalent

Pin No.	Assignment	Mating Housing	Terminal
1	5VSB	TKP DH2 or equivalent	TKP or equivalent
2,4	DC COM		
3	PS-ON		

Function Connector(CN11): TKP DH2I-2X2 or equivalent

Pin No.	Assignment	Mating Housing	Terminal
1	-S	TKP DH2 or equivalent	TKP or equivalent
2	+S		
3	DC COM		
4	PG		

FAN Connector(CN12) : TKP 8812-2 or equivalent

Pin No.	Assignment	Mating Housing	Terminal
1	DC COM	TKP 2502 or equivalent	TKP 8811 or equivalent
2	+12V		

⏏ Grounding Required

⚠ HS1,HS2,HS3,HS4 can not be shorted

⊗ Note: When the input voltage is AC 230V the model delivers EMI Class B for both conducted emission and radiated emission for the power supply, When the input voltage is AC110V the model delivers EMI Class B for conducted emission ,Class A for radiated emission for the power supply.  
It delivers Class A for conduced emission and radiated emission, when configured into Class II (without FG) system.

**Installation Manual**

Please refer to : <http://www.meanwell.com/webnet/search/InstallationSearch.html>