



- Features :
- Universal AC input / Full range
- Built-in active PFC function
- Protections: Short circuit / Overload / Over voltage
- Cooling by free air convection
- Built-in constant current limiting circuit
- 1U low profile 30mm
- Remote ON-OFF control
- LED indicator for power on
- Over voltage category III
- 100% full load burn-in test
- 3 years warranty



SPECIFICATION

MODEL	RSP-75-3.3	RSP-75-5	RSP-75-7.5	RSP-75-12	RSP-75-13.5	RSP-75-15	RSP-75-24	RSP-75-27	RSP-75-48	
OUTPUT	DC VOLTAGE	3.3V	5V	7.5V	12V	13.5V	15V	24V	27V	48V
	RATED CURRENT	15A	15A	10A	6.3A	5.6A	5A	3.2A	2.8A	1.6A
	CURRENT RANGE	0 ~ 15A	0 ~ 15A	0 ~ 10A	0 ~ 6.3A	0 ~ 5.6A	0 ~ 5A	0 ~ 3.2A	0 ~ 2.8A	0 ~ 1.6A
	RATED POWER	49.5W	75W	75W	75.6W	75.6W	75W	76.8W	75.6W	76.8W
	RIPPLE & NOISE (max.) Note.2	80mVp-p	80mVp-p	80mVp-p	120mVp-p	120mVp-p	120mVp-p	120mVp-p	120mVp-p	200mVp-p
	VOLTAGE ADJ. RANGE	3.14 ~ 3.63V	4.75 ~ 5.5V	7.13 ~ 8.25V	11.4 ~ 13.2V	12.8 ~ 14.9V	14.3 ~ 16.5V	22.8 ~ 26.4V	25.7 ~ 29.7V	45.6 ~ 52.8V
	VOLTA GE TOLERANCE Note.3	±2.0%	±2.0%	±2.0%	±2.0%	±2.0%	±2.0%	±1.0%	±1.0%	±1.0%
	LINE REGULATION	±0.5%	±0.5%	±0.5%	±0.5%	±0.5%	±0.5%	±0.5%	±0.5%	±0.5%
	LOAD REGULATION	±1.0%	±1.0%	±1.0%	±0.5%	±0.5%	±0.5%	±0.5%	±0.5%	±0.5%
	SETUP, RISE TIME	600ms, 30ms at full load								
HOLD UP TIME (Typ.)	16ms at full load									
INPUT	VOLTAGE RANGE	85 ~ 264VAC		120 ~ 370VDC						
	FREQUENCY RANGE	47 ~ 63Hz								
	POWER FACTOR (Typ.)	PF>0.93/230VAC		PF>0.98/115VAC at full load						
	EFFICIENCY (Typ.)	76%	82%	84%	85%	85%	86%	87%	88%	89%
	AC CURRENT (Typ.)	0.9A/115VAC		0.5A/230VAC						
	INRUSH CURRENT (Typ.)	COLD START 35A/230VAC								
	LEAKAGE CURRENT	<2mA / 240VAC								
PROTECTION	OVERLOAD	105 ~ 135% rated output power Protection type : Constant current limiting, recovers automatically after fault condition is removed								
	OVER VOLTAGE	3.63 ~ 4.46V	5.5 ~ 6.75V	8.25 ~ 10.13V	13.2 ~ 16.2V	14.85 ~ 18.23V	16.5 ~ 20.25V	26.4 ~ 32.4V	29.7 ~ 36.45V	52.8 ~ 64.8V
	OVER TEMPERATURE	Shut down o/p voltage, recovers automatically after temperature goes down								
FUNCTION	REMOTE CONTROL	CN1: < 0~0.8VDC POWER ON , 4~10VDC POWER OFF								
ENVIRONMENT	WORKING TEMP.	-25 ~ +70°C (Refer to "Derating Curve")								
	WORKING HUMIDITY	20 ~ 90% RH non-condensing								
	STORAGE TEMP., HUMIDITY	-40 ~ +85°C, 10 ~ 95% RH non-condensing								
	TEMP. COEFFICIENT	±0.05%/°C (0 ~ 50°C)								
	VIBRATION	10 ~ 500Hz, 2G 10min./1cycle, 60min. each along X, Y, Z axes								
SAFETY & EMC (Note 4)	OVER VOLTAGE CATEGORY	III ; According to EN61558, EN50178, EN60664-1, EN62477-1 ; altitude up to 2000 meters								
	SAFETY STANDARDS	UL60950-1, TUV EN60950-1, EN61558-1, EN61558-2-16, CCC GB4943 approved								
	WITHSTAND VOLTAGE	I/P-O/P:4KVAC		I/P-FG:2KVAC		O/P-FG:0.5KVAC				
	ISOLATION RESISTANCE	I/P-O/P, I/P-FG, O/P-FG:100M Ohms / 500VDC / 25°C / 70% RH								
	EMC EMISSION	Compliance to EN55032 (CISPR32) Class B, EN61000-3-2,-3, GB9254 class B								
	EMC IMMUNITY	Compliance to EN61000-4-2,3,4,5,6,8,11, EN55024, light industry level, criteria A								
OTHERS	MTBF	296.7K hrs min. MIL-HDBK-217F (25°C)								
	DIMENSION	159*97*30mm (L*W*H)								
	PACKING	0.44Kg; 30pcs/14.2Kg/0.91CUFT								
NOTE	<ol style="list-style-type: none"> All parameters NOT specially mentioned are measured at 230VAC input, rated load and 25°C of ambient temperature. Ripple & noise are measured at 20MHz of bandwidth by using a 12" twisted pair-wire terminated with a 0.1uf & 47uf parallel capacitor. Tolerance : includes set up tolerance, line regulation and load regulation. The power supply is considered a component which will be installed into a final equipment. The final equipment must be re-confirmed that it still meets EMC directives. For guidance on how to perform these EMC tests, please refer to "EMI testing of component power supplies." (as available on http://www.meanwell.com) 									

Case No.227A Unit:mm

Mechanical Specification

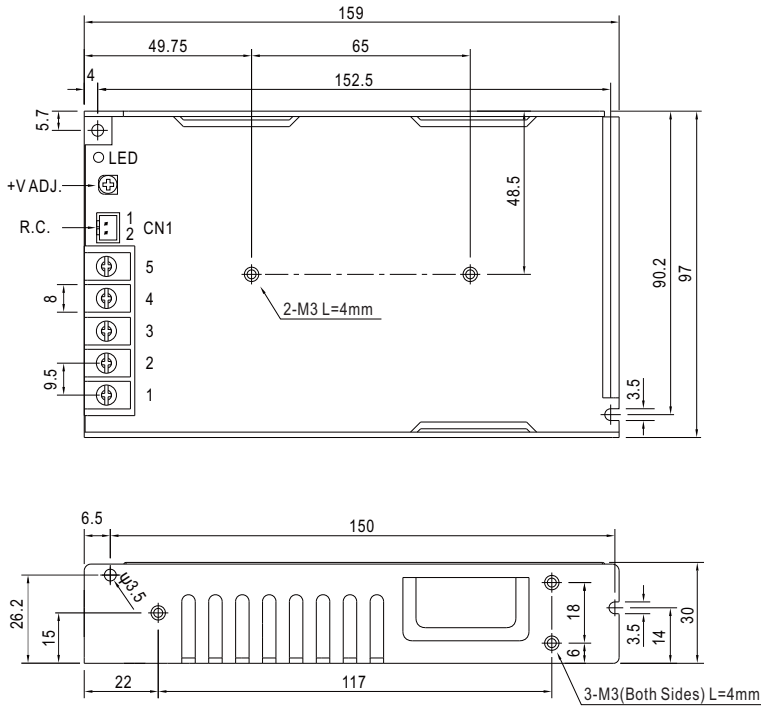

Terminal Pin No. Assignment

Pin No.	Assignment	Pin No.	Assignment
1	AC/L	4	DC OUTPUT -V
2	AC/N	5	DC OUTPUT +V
3	FG		

Remote ON/OFF(CN1): JST S2B-XH or equivalent(optional)

Pin No.	Assignment	Mating Housing	Terminal
1	RC+	JST XHP or equivalent	JST SXH-001T-P0.6 or equivalent
2	RC-		

Block Diagram

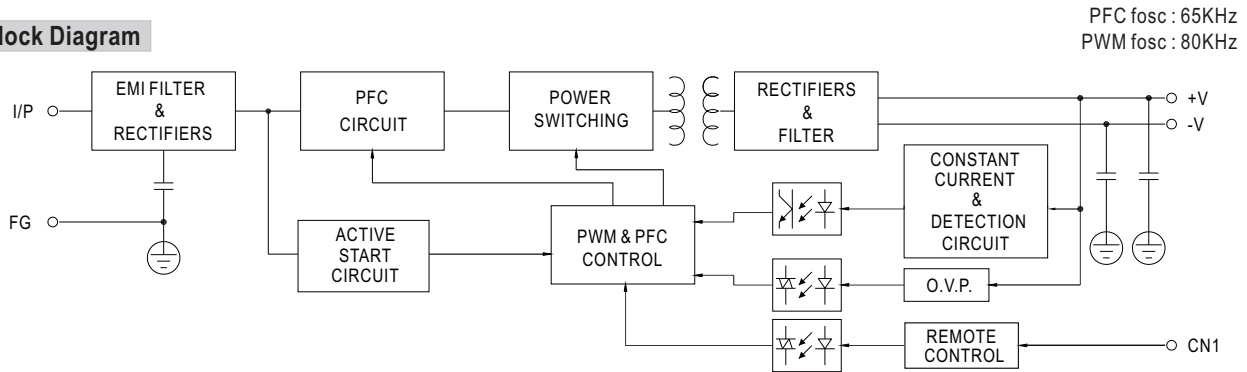

Derating Curve

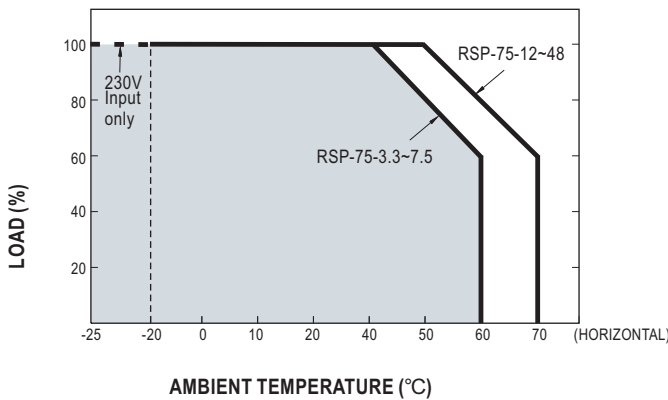

Output Derating VS Input Voltage

